

PCL451 - Manual Preset Indexer



FEATURES

- **Internal Index Count Switches**
- **Pulse Rates up to 14,792 Pulses per second**
- **CW and CCW Home, Hard and Soft Limit Inputs**
- **Adjustable Motion “Complete” Output**
- **Motion “Busy” Output**
- **Clock Pulses and Step Direction Outputs**
- **CW and CCW Index Inputs**
- **CW and CCW Jog/Run and Fast Job Inputs**
- **Two “Go to Home Position” Modes**
- **TTL-MOS Compatible**
- **Index on the Fly**



DESCRIPTION

The PCL451 contains a manual preset indexer board. Figure 1 shows the general configuration and layout of a preset indexer system. The thumbwheel switch is used to set the index (number of steps or move distance) and the manual switches and/or PLC are used to initiate indexing, homing or jogging. The manual preset indexer board utilizes the PI45 preset indexer integrated circuit (IC). Available functions include home, hard and soft limit inputs, two homing modes, jog/run, fast jog and switch selectable base speed, maximum speed, and acceleration/deceleration. This board includes the necessary buffering and other circuitry for the PI45 chip that makes indexing easy. The board can be operated manually or with a programmable logic controller (PLC) to index a set of pulses determined by the internal count switches or an external count module, such as the AA1760-5 or similar device.

DIMENSIONS

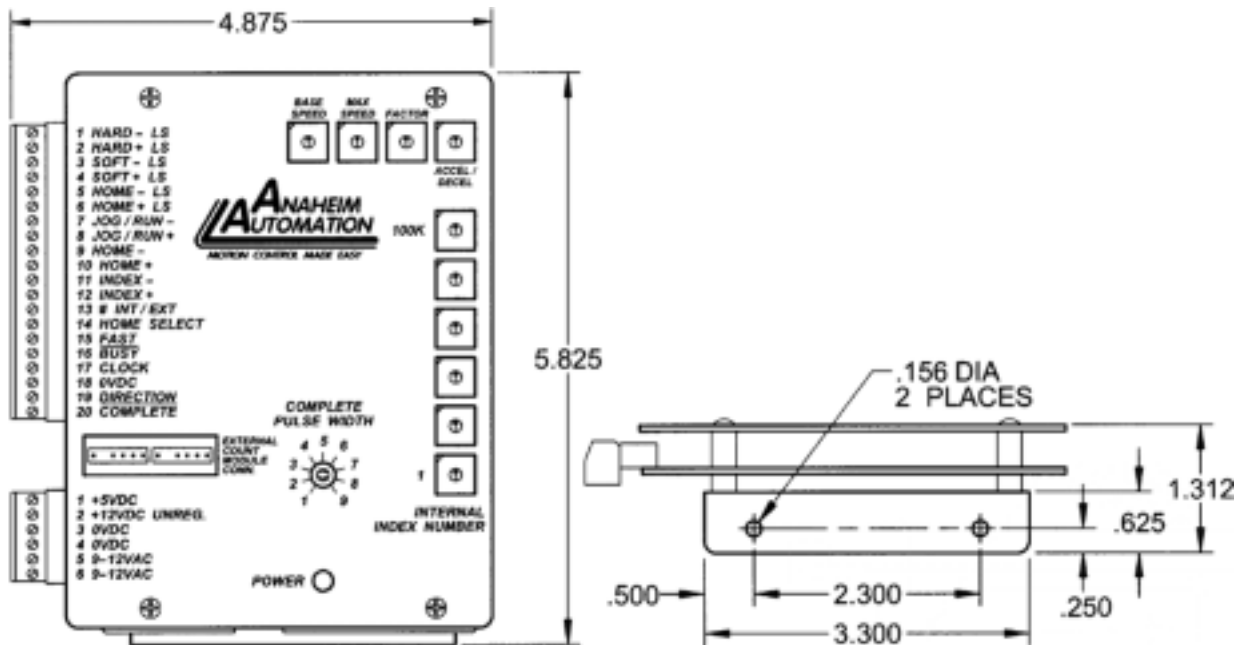

L010644

Wiring Diagram

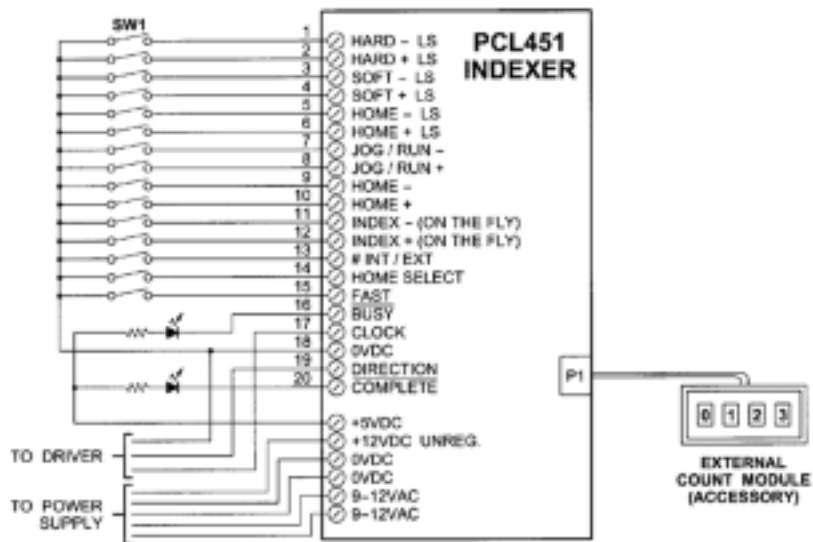

Specifications

Power Requirements: 9-12VAC - pins 5 & 6 TB2
 +5VDC - pin 1 TB2
 or +9VDC to +15VDC - pin 2 TB2
 total current drawn from pin 1 & 2 must not exceed 500mA

Control Inputs: All input Terminals are pulled up to +5VDC through 1k ohm resistors
 TTL-MOS Compatible
 Logic "0": 0VDC to 0.8VDC
 Logic "1": 3.5VDC to 5.0VDC

Ambient Temperature: 0 to 50 degrees C