

# TSMNA42 Series Linear Actuators

## FEATURES

- **Competitively priced, high resolution digital non-captive linear actuators**
- **Linear force up to 22.5 lbs (100N)**
- **Linear step resolution of .001", .002" and .004"**
- **Unipolar and bipolar coil constructions**
- **Fast, powerful and precise positioning**
- **Precision radial ball bearing design**
- **Industry standard frame size**
- **Customized designs available**
- **CE Certified and RoHS Compliant**



## DESCRIPTION

The TSMNA42 Series Non-Captive Linear Actuators are the perfect choice for cost effective linear motion. The stepper motor internally converts rotary motion to linear motion via a rotating nut and a leadscrew. This actuator eliminates the need for other rotary-to-linear conversions such as belt and pulleys, rack and pinions, or external ball screws. Motion designs can be simplified, production costs lowered and product life enhanced. The motors can be customized to fit your machine requirements. The motor comes in a standard 6-lead configuration and is available in a 4-lead configuration. We can also customize the winding to perfectly match your voltage, current, and maximum operating speed. Special screw modifications, cables and connectors are also available upon request.

## SPECIFICATIONS

Model #	DC Operating Voltage (V)	Linear Travel Per Step (in)	Maximum Force (lbs)	Minimum Holding Force (lbs)	Maximum Travel (in)	Bipolar Resistance Per Phase (ohm)	Bipolar Inductance Per Phase (mH)	Bipolar Current (A)	Weight (oz)
TSMNA42-010-24-100-LW6	5	0.001	22.5	25.0	2.4	10	14.8	0.70	5.5
TSMNA42-040-24-100-LW6	5	0.004	11.24	4.38	2.4	10	14.8	0.70	5.5

L010447

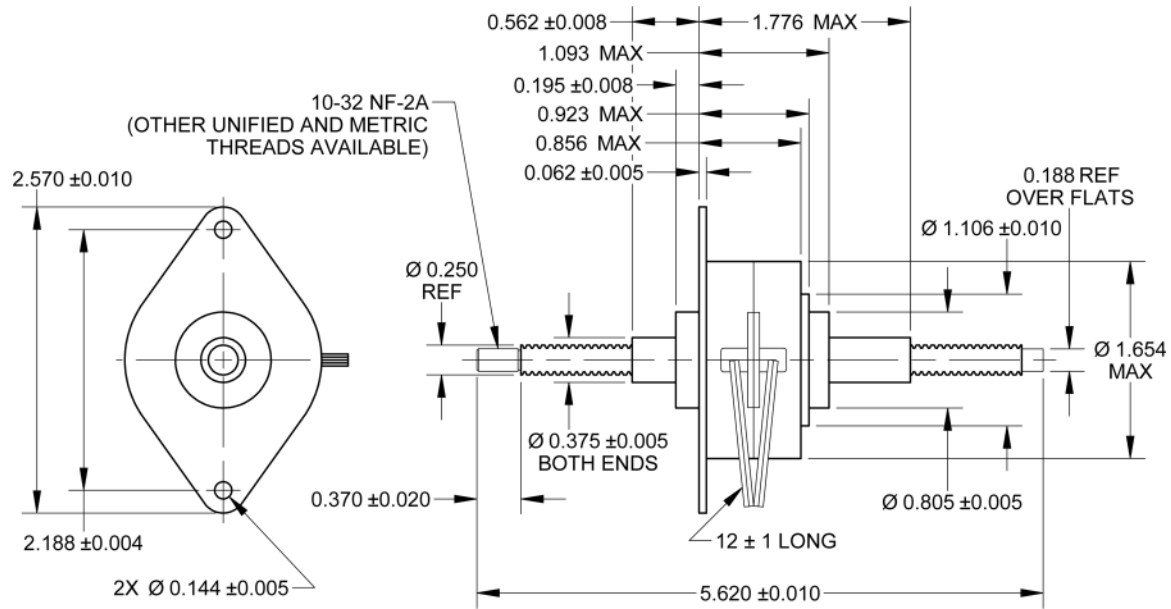

DIMENSION

WIRING INFORMATION

SPECIFICATIONS

Connection	Lead Wire Connection	Lead Wire Color
4 - Lead Bipolar Series MBC Series	Phase 1 (A)	Yellow
	Phase 3 (/A)	Orange
	Phase 2 (B)	Brown
	Phase 4 (/B)	Black
	No Connect	Red
6 - Lead Unipolar BLD, TM Series	No Connect	Green
	Phase 1	Yellow
	Phase 3	Orange
	Phase 2	Brown
	Phase 4	Black
	Common Phase 1 & 3	Red
	Common Phase 2 & 4	Green

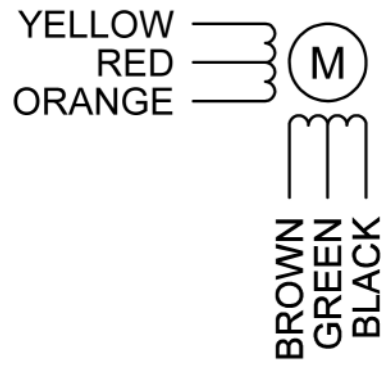

Max Pull-in Rate* (Steps/Sec)	300
Power Consumption:	10 Watts
Insulation Resistance:	20 M-ohms
Bearings:	Radial Ball
Weight:	5.5 oz (156gm)
Operating Temperature Range:	-20°C to 70°C
Storage Temperature Range	-40°C to 85°C

\*Measured with 2 phases energized