

TGM28-056-19-12V-004A-64R-LW4



- Permanent Magnet Stepper GearMotor
- High torque in a Small Package at a Low Cost
- 300 g-cm of Torque
- 64:1 gear Ratio
- 28 mm diameter

Specifications

Item	Specifications
Step Angle Accuracy	±7% (full step, no load)
Resistance Accuracy	±10%
Inductance Accuracy	±20%
Temperature Rise	80° C Max
Ambient Temperature	-20°C to +50°C
Insulation Resistance	100MOMin. ,500VDC
Dielectric Strength	500VAC for one minute

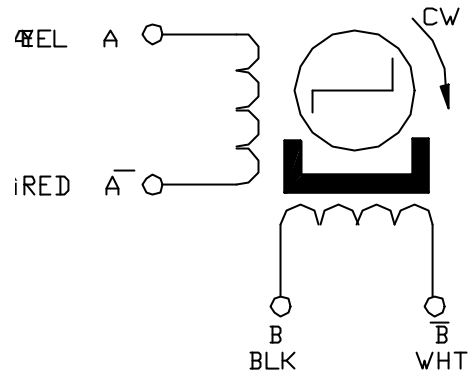

Model	Step Angle (deg)	Gear Ratio	# of Wires	Voltage (V)	Current per Phase (A)	Holding Torque (g.cm)	Detent Torque (g.cm)
TGM28-056-19-12V-004A-64R-LW4	5.625	64:1	4	12	0.04	300	200

