

# MBL536 BILEVEL STEP MOTOR DRIVER

- ! 10 Amperes/phase Maximum Operating Current
- ! 7 Amperes/phase Standstill motor current
- ! Half-step and Full-step Operation
- ! Bilevel Drive Operation
- ! No RFI or EMI problems
- ! TTL/CMOS Compatible Inputs
- ! Clock and Direction or Dual Clock Operation
- ! Motor Turn-off Input
- ! Compact and Rugged

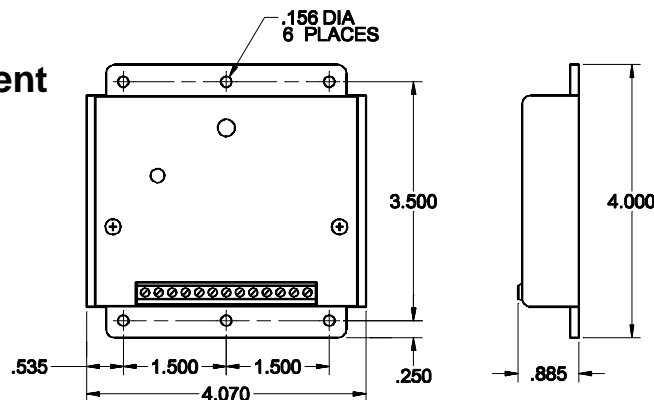

FIGURE 1: MBL536 DIMENSIONS

## GENERAL DESCRIPTION

The ANAHEIM AUTOMATION MBL536 is an improved version of the MBL500 series step motor drivers. The MBL536 with its compactness and attractive rugged package style employs bilevel (or dual voltage) drive technique for high performance operation of step motors providing significantly improved motor speed torque output. *New features include selectable "+" or "-" going clock inputs, transient voltage protection, and improved Full-step operation.*

## BILEVEL DRIVE

The basic function of a step motor driver is to control the motor winding currents. Motor performance is determined by how fast the driver can increase and decrease the winding currents. A rapid rise in winding current is achieved by applying a high voltage directly to a motor. This rapid rise of current is also referred to as the "kick" or operating current. When a desired current level is reached, a low voltage is applied to maintain a suitable holding current level. When a motor winding is turned off, a rapid decrease in winding current is achieved by routing the energy in the collapsing field back to the power supply through a high voltage path. The high voltage supply furnishes the

energy necessary to maintain motor output torque at high step rates thus providing high mechanical power output. The low voltage supply provides much of the current needed at low step rates and all of the holding current.

## EXCITATION MODE OPTION

Users have a choice of dual-phase, full-step operation or half-step operation. Dual-phase, full-step operation occurs by energizing two phases at a time, rotating a typical motor 1.8 degrees per step. Half-step operation occurs by alternately energizing one, and then two, phases at a time, rotating the motor 0.9 degrees per step. Half-step is the recommended mode of operation. Full-step operation is only suggested for applications that specifically require that mode, such as when retrofitting existing full-step systems.

## STEP AND DIRECTION CONTROL

The MBL536 has two clock options: Clock and Direction or Dual Clock operation. Terminal 5 can be configured as the Direction Input or CCW Clock Input by placing jumper JP1 in the appropriate position (see Table 1 And Figure 2). Pulses applied to the Clock Input cause the

motor to step in the clockwise direction if the Direction Input is a logic "1" or the counterclockwise direction if the Direction Input is a logic "0". Pulses applied to the CCW Input cause the motor to step in the counterclockwise direction. Either positive or negative going pulses may be used by setting JP2 to the appropriate position (See Table 1 and Figure 2).

## MOTOR ON/OFF OPTION

The MOTOR ON/OFF option allows de-energizing a motor without disturbing the positioning logic. After reenergizing the motor, a routine can continue. This reduces motor heating and conserves power, especially in applications where motors are stopped for long periods and no holding torque is required.

## MOTOR CONNECTIONS

Hookup diagrams for a motor driver application are presented in Figures 3 and 4. *Wiring connected to inputs must be separated from motor connections and all other possible sources of interference.*

**IMPORTANT NOTE:** When the wiring from the driver to the step motor extends beyond 25 feet, consult the factory.

**TRANSIENT VOLTAGE SUPPRESSION**

Transient Voltage Suppression (TVS) Diodes on the motor phase outputs allow for much longer motor cables to be used. Normally when using long motor cables, voltage transients and spikes are created. These transients often exceed the voltage ratings of the output phase transistors, resulting in blown transistors. The addition of the TVS Diodes suppresses these transients and protect the transistors against damage.

**DETERMINING LOW-VOLTAGE SUPPLY LEVEL**

The Low Voltage (Vlv) supply furnishes the current necessary for holding (standstill) torque and low-speed running torque. Table 2 shows the current ranges for all compatible Anaheim Automation motors. Higher values for the Low Voltage will produce more holding and low-speed torque. A proper Vlv will produce a standstill current that is 65 to 100% of the rated motor current (i.e. for a motor rated at 1 amp, Vlv should be set so that the standstill current is 0.65 to 1 amps).

**VERIFYING STANDSTILL MOTOR CURRENT**

To check the standstill current do the following:

1. Apply power to the driver with motor connected, but do not apply clock pulses.
2. Select Full-step mode (ground terminal 8 to 0V). This will assure that two phases will be on.
3. Measure the voltage across resistors R1 and R2
4. Multiply the readings by 20 to calculate the standstill current. (i.e. if the voltage across R1 and R2 reads 0.250V, the standstill current is 0.250x20=5.00 Amps)

**DETERMINING HIGH-VOLTAGE SUPPLY LEVEL**

The high-voltage supply (Vhv) can range from 24Vdc to 70Vdc. Vhv determines high-speed torque performance and acceleration.

**ADJUSTING KICK CURRENT**

By following the silkscreen instructions on the cover of the MBL536 driver, use a small screwdriver to adjust the potentiometer. Line up the arrow to the number corresponding to the motor's rated current (amps/phase).

**TORQUE CURVES**

Torque curves are shown on the back of this specification sheet. This data was obtained using a high voltage (Vhv) of approximately 60Vdc no load. The low voltage (Vlv) used was an unregulated voltage of about 5.5Vdc no load. Both voltages dropped when loaded.

To obtain more torque at high speeds, Vhv should be increased. To obtain more torque at standstill and low speeds, Vlv should be increased *but the motor current at standstill should not exceed the motor's rated current.*

FUNCTION	JP1	JP2
TERMINAL 5 = DIRECTION	2 - 3	X
TERMINAL 5 = CCW	1 - 2	X
POSITIVE GOING CLOCKS	X	2 - 3
NEGATIVE GOING CLOCKS	X	1 - 2
STANDARD PRODUCT	2 - 3	2 - 3

TABLE 1: JUMPERS SETTINGS

X=DON'T CARE

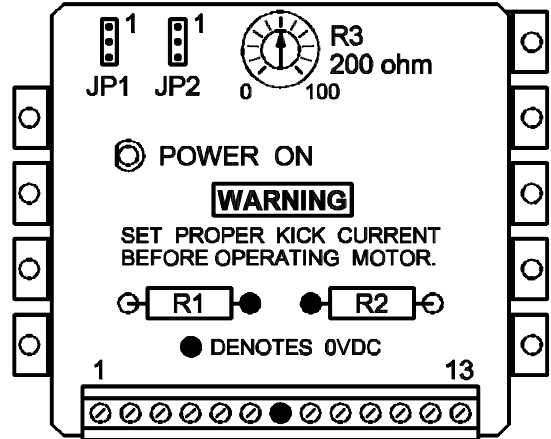

FIGURE 2: JUMPER LOCATIONS

MOTOR PART NUMBER	CURRENT RATING (AMPS)	VLV RANGE
23D102	1.0	4.5V - 7.0V
23D104	2.0	3.5V - 5.2V
23D108	3.9	2.5V - 3.3V
23D204	1.8	4.1V - 6.2V
23D209	4.7	2.7V - 3.7V
23D306	2.9	4.0V - 5.9V
23D309	4.6	3.2V - 4.5V
34D106	3.0	3.3V - 4.8V
34D109	4.8	2.7V - 3.8V
34D207	3.5	4.0V - 6.2V
34D209	4.6	3.3V - 4.7V
34D307	3.5	4.0V - 6.0V
34D311	5.5	3.6V - 5.3V
34D314	7.0	3.4V - 4.9V
42D112	6.1	2.9V - 4.0V
42D212	6.1	4.1V - 6.1V

TABLE 2: LOW VOLTAGE VALUES FOR ANAHEIM AUTOMATION STEP MOTORS.

## SPECIFICATIONS

### Control Inputs (All) : (Terminals 5, 6, 8, 9)

TTL-compatible

Logic "0" - 0 to 0.8 V

Logic "1" - 3.5 to 5.0 V

### Clock Inputs : (Terminals 5 & 6)

Pulse required; 15 microseconds minimum. The clock input is pulled up internally to +5Vdc through a 10K  $\Omega$  resistor for negative going clock input, or pulled down to 0Vdc through a 10K  $\Omega$  resistor for positive going clock input.

### Direction Control: (Terminal 5)

Logic "1" (open) - CW

Logic "0" - CCW

### Excitation Mode Select: (Terminal 8)

Logic "1" - Half-step

Logic "0" - 2  $\phi$  Full-step

### Power ON/OFF: (Terminal 9)

Logic "1" (open) - motor current on

Logic "0" - motor current off

### Output Current Rating:

#### (Terminals 1, 2, 3, 11, 12, & 13)

6.5 Amps per phase, maximum, over the operating voltage and temperature range. Motor phase ratings of 1.0 Amp minimum are required to meet the minimum kick level.

### Power Requirements :

Low-voltage supply (Vlv) typically ranges between 3.5 and 6.5 Vdc. The maximum allowable low-voltage is **10Vdc**. (See para DETERMINING LOW-VOLTAGE SUPPLY LEVEL).

High-voltage supply (Vhv) is 55 Vdc nominal, 10 Vdc minimum and, **70 Vdc maximum**. (See para DETERMINING HIGH-VOLTAGE SUPPLY LEVEL).

### Operating Temperature : 0 to 60 degrees C

It is recommended that the unit be mounted on a larger aluminum plate, or similar heat-conducting structure, whenever possible. This will prevent the driver from overheating and degrading driver reliability. Fan cooling is also recommended whenever possible.

The MBL536 requires a power supply kit. Consult the factory for the best driver, power supply and motor application.

Anahiem Automation offers a color-coded cable for easy step motor hookups.. This 16 gauge, 6 conductor cable is PVC insulated, with color-coded conductors; the same color as the leads on Anahiem Automation step motors(red, red/white, green, green/white, black and white). The cable is shielded, and available in 25 feet increments, Part Number AA129011-S

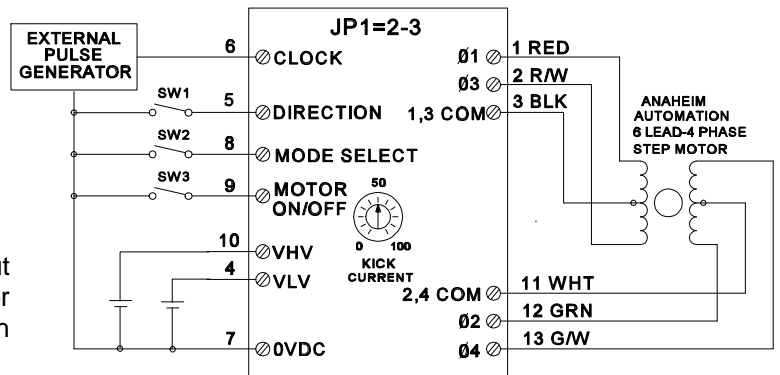

FIGURE 3: TYPICAL HOOKUP DIAGRAM USING CLOCK AND DIRECTION.

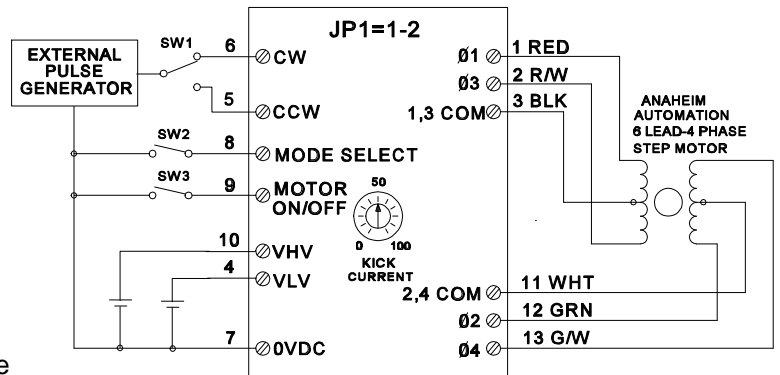

FIGURE 4: TYPICAL HOOKUP DIAGRAM USING CW AND CCW.