

MBC25081 Bipolar Microstep Driver

SPEC SHEET

- 2.5 Amps/Phase Output Current
- Bipolar Microstepping Drive Operation
- Over Temperature and Short Circuit Shutdown
- Microstep Divisors of 8, 4, 2, or Full Step
- Compact Package: 2.35" x 2.26" x 0.92"
- 12-24VDC Power Requirement
- Accepts TTL Logic or 24V Level Inputs
- Ideal for Precise Positioning
- Efficient and Durable
- Long Life Expectancy



The MBC25081 is a 2.5 amps/phase bipolar microstep driver capable of running four, six, and eight lead step motors. The MBC25081 has an output current range of 0.5 to 2.5 amps/phase and operates off 12VDC minimum to 24VDC maximum. The inputs are capable of running from either open collector or TTL level logic outputs, or sourcing 24VDC outputs from PLCs. The MBC25081 features resolutions from 200 - 1600 steps/revolution, providing smooth rotary operation. The MBC25081 features include built in over temperature and short circuit shut down, automatic 70% reduction in current after clock pulses stop being received, and status LED's to indicate power on (green LED) and clocks being received (yellow LED). The MBC25081 is a compact, low profile package meant to be used where space is limited but performance is expected.

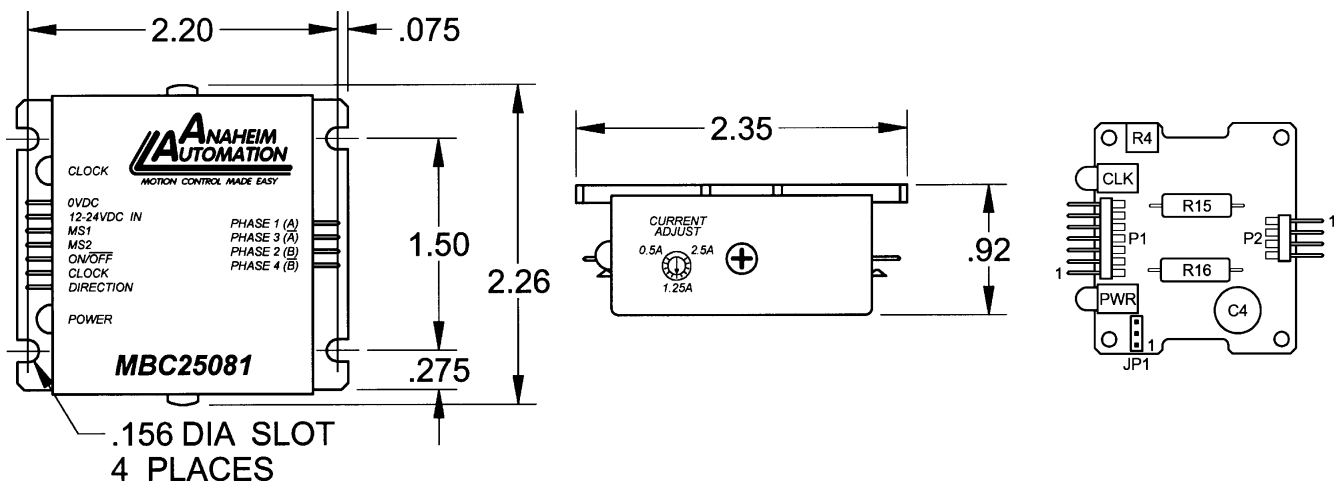

Ordering Information	
Part Number	Description
MBC25081	12-24VDC, 0.5-2.5A Bipolar Microstep Driver, Packaged with Heat Sink
MBC15081	12-24VDC, 0.3-1.5A Bipolar Microstep Driver, Open-Frame
CBL-AA4031	7 Pin Input Connector with 12", 22AWG Leads
CBL-AA4033	4 Pin Motor Connector with 12", 22AWG Leads
PSAM24V2.7A	24V @ 2.7A Universal Input Power Supply
CON-6404407	7 Pin Connector with 0.100" Centers (Amp #640440-7)
CON-6404404	4 Pin Connector with 0.100" Centers (Amp #640440-4)



ANAHEIM AUTOMATION

910 East Orangefair Lane, Anaheim, CA 92801
e-mail: info@anaheimautomation.com

(714) 992-6990 fax: (714) 992-0471
website: www.anaheimautomation.com

Hook-Up Drawings

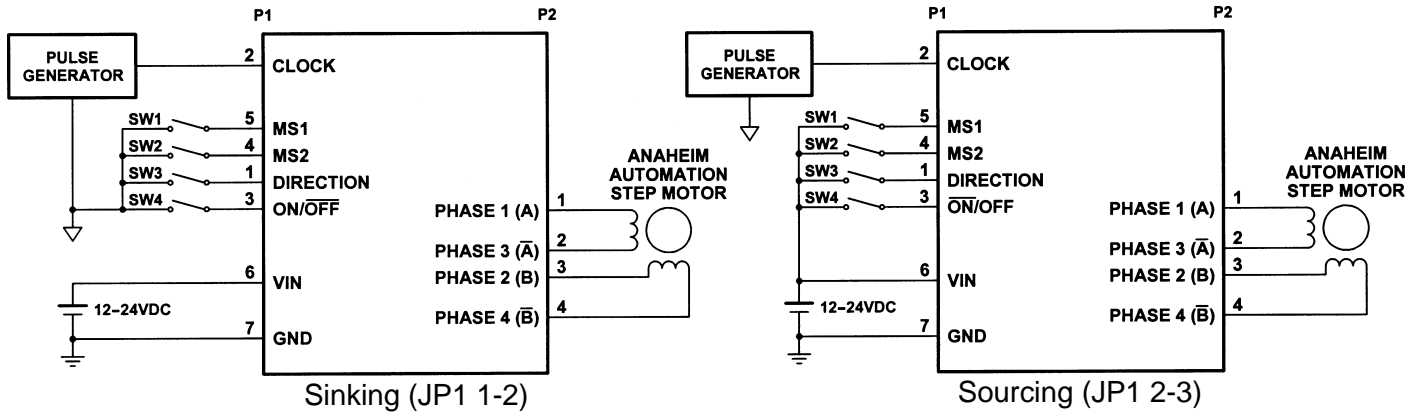

Input Pin Descriptions		
Pin #	Description	CBL-AA4031 Wire Color
1	Direction	Brown
2	Clock	Red
3	On/Off	Orange
4	MS2	Yellow
5	MS1	Green
6	12VDC-24VDC	Blue
7	0VDC (Gnd)	Violet

Motor Pin Descriptions		
Pin #	Description	CBL-AA4033 Wire Color
1	Phase A	Brown
2	Phase A-bar	Red
3	Phase B	Orange
4	Phase B-bar	Yellow

Control Inputs (Pins 1, 2, 3, 4, 5):

Microstep Resolution Truth Table		
MS1	MS2	Resolution
Active	Active	Full Step
Inactive (Open)	Active	Half Step
Active	Inactive (Open)	Quarter Step
Inactive (Open)	Inactive (Open)	Eighth Step

- Direction:** Logic "1" CW
Logic "0" CCW
- Clock:** Active - 1 Step
Inactive (open) - Reduce Current Mode
- On/Off:** Active - Off
Inactive (open) - On

Notes:
Open Inputs are inactive and internally pulled up to +5VDC for JP1 position 1-2 (Sinking)
Open Inputs are inactive and internally pulled down to 0VDC for JP1 position 2-3 (Sourcing)

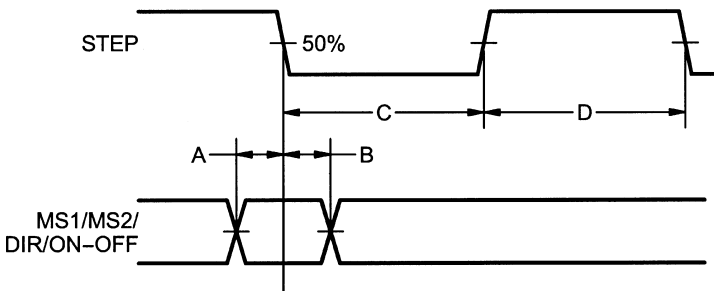

- A. Minimum Command Active Time Before Clock Pulse (Data Set-Up Time) ... 200nS
- B. Minimum Command Active Time After Clock Pulse (Data Hold Time) 200nS
- C. Minimum CLOCK Pulse Width 1.0uS
- D. Minimum CLOCK Inactive Time 1.0uS
- Maximum CLOCK Frequency 500kHz

With JP1 in position 1-2 (sinking) the inputs are considered inactive or Logic "1" if left open, or active or Logic "0" if grounded. With JP1 in position 2-3 (sourcing) the inputs are considered inactive or Logic "0" if left open, and active or Logic "1" if pulled to 3.5 - 24VDC.

Setting the Output Current

The output current on the MBC25081 is set by the onboard potentiometer. This potentiometer determines the per phase peak output current of the driver. The relationship between the output current and the potentiometer value is as follows:

WARNING! Step motors will run hot even when configured correctly. Damage may occur to the motor if a higher than specified current is used. Most specified motor currents are maximum values. Care should be taken to not exceed these ratings.

MBC25081 Potentiometer Settings

Peak Current	Potentiometer Setting	Peak Current	Potentiometer Setting
0.50A	0%	1.70A	60%
0.70A	10%	1.90A	70%
0.90A	20%	2.10A	80%
1.10A	30%	2.30A	90%
1.30A	40%	2.50A	100%
1.50A	50%	--	--

Reducing Output Current

Reducing the output current is accomplished automatically and occurs approximately 20mSec after the last the clock input has been received. The amount of current per phase in the reduction mode is approximately 70% of the set current. When the current reduction circuit is activated, the current reduction resistor is paralleled with the current adjustment potentiometer. This lowers the total resistance value, and thus lowers the per phase output current.

Connecting the Step Motor

Phase 1 and Phase 3 of the step motor are connected to pins 1 and 2 on connector P2. Phase 2 and Phase 4 of the step motor are connected to pins 3 and 4 on connector P2. Please refer to the figure for a TYPICAL APPLICATION HOOK-UP.

Note: The physical direction of the motor with respect to the direction input will depend on the connection of the motor windings. To reverse the direction of the motor with respect to the direction input, switch the wires on Phase 1 and Phase 3.

WARNING: DO NOT CONNECT OR DISCONNECT MOTOR WIRES WHILE POWER IS APPLIED!

Motor Selection

The MBC25081 is a Bipolar Microstep Driver that is compatible with both Bipolar and Unipolar Motor Configurations, (i.e. 8 and 4 lead motors, and 6 lead center tapped motors).

Step motors with low current ratings and high inductance will perform better at low speeds, providing higher low-end torque. Motors with high current ratings and low inductance will perform better at higher speeds, providing more high-end torque.

Since the MBC25081 uses a constant current source drive technique, it is not necessary to use a motor that is rated at the same voltage as the supply voltage. What is important is that the potentiometer is set to the appropriate current level based on the motor being used. Higher voltages will cause the current to flow faster through the motor coils. This in turn means higher step rates can be achieved. **Care should be taken not to exceed the maximum voltage of the driver.**

Step Motor Configurations

Step motors can be configured as 4, 6, or 8 leads. Each configuration requires different currents. Refer to the lead configurations and the procedures to determine their output current.

Determining Output Current

The output current for a motor used with a bipolar driver is determined differently from that of a unipolar driver. In the MBC25081, a sine/cosine output function is used in rotating the motor. The output current for a given motor is determined by the motors current rating and the wiring configuration of the motor. There is a current adjustment potentiometer used to set the output current of the MBC25081. This sets the peak output current of the sine/cosine waves. The specified motor current (which is the unipolar value) is multiplied by a factor of 1.0, 1.4, or 2.0 depending on the motor configuration (series, half-coil, or parallel).

6 Lead Motors

Half-Coil Connection: When configuring a 6 lead motor in half-coil (connected from one end of the coil to the center tap), multiply the specified per Phase (or unipolar) current rating by 1.4 to determine the current setting potentiometer value. This configuration will provide more torque at higher speeds when compared to the series configuration.

Series: When configuring the motor in series (connected from end to end with the center tap floating) use the specified per Phase (or unipolar) current rating to determine the current setting potentiometer value.

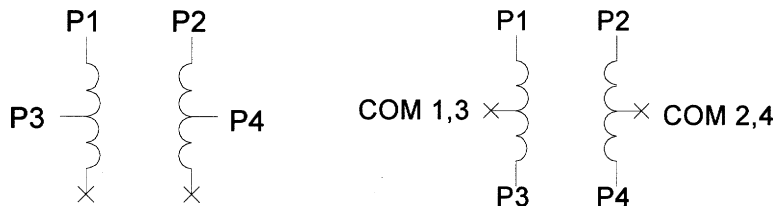

8 Lead Motors

Series Connection: When configuring the motor windings in series, use the per Phase (or unipolar) current rating to determine the current setting potentiometer value.

Parallel Connection: When configuring the motor windings in parallel, multiply the per Phase (or unipolar) current rating by 2.0 to determine the current setting potentiometer value.

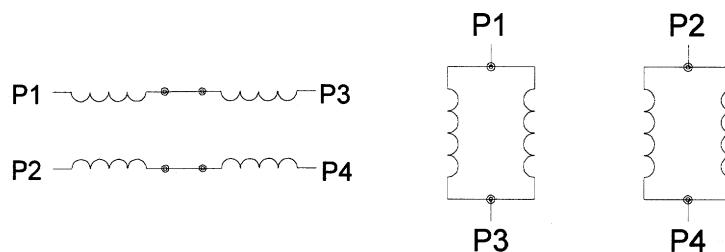

4 Lead Motors

Series Connection: Multiply the specified series motor current by 1.4 to determine the current adjustment potentiometer value. Four Lead Motors are usually rated with their appropriate series current, as opposed to the *Phase Current*, which is the rating for 6 and 8 lead motors.

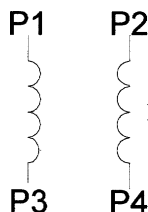

Connecting to the MBC25081

The MBC25081 is designed with cost savings and size as two of the primary design criteria. For this reason, the MTA-100 series connector was chosen for these products as a reliable small and low cost connector. This is a common Insulation Displacement Connector (IDC) manufactured by AMP Corporation. The inputs to the driver are on a 7-pin connector and the motors are on a 4-pin connector. These connectors are not supplied with the driver, but can be purchased from Anaheim Automation or AMP/Tyco Electronics.

These two images show how a hand tool can be used to quickly make the cable to connect to the driver. This cable can be made in approximately 10 seconds per wire using the hand tool.

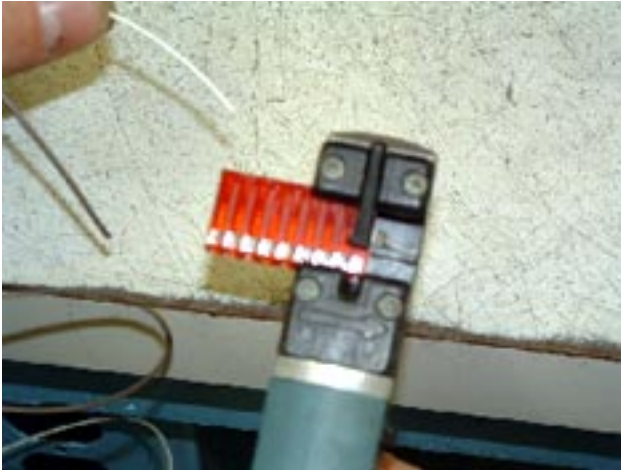

Tooling from AMP/Tyco Electronics

Part Number	Description
58074-1	Manual Hand Tool with Interchangeable Head (shown above)
58075-1	Air Hand Tool with Interchangeable Head
58338-1	Air Bench Mount Tool with Interchangeable Head and Foot Switch
58246-1	Die Head for Closed End MTA-100 Connectors (shown above)

Connectors from AMP/Tyco Electronics

Part Number	Description
640440-7	7 Pin MTA-100 Connector, Closed End with Lock, 22 AWG Red, Tin Plated
640440-4	4 Pin MTA-100 Connector, Closed End with Lock, 22 AWG Red, Tin Plated
640441-7	7 Pin MTA-100 Connector, Closed End with Lock, 24 AWG White, Tin Plated
640441-4	4 Pin MTA-100 Connector, Closed End with Lock, 24 AWG White, Tin Plated
640442-7	7 Pin MTA-100 Connector, Closed End with Lock, 26 AWG Blue, Tin Plated
640442-4	4 Pin MTA-100 Connector, Closed End with Lock, 26 AWG Blue, Tin Plated