

MBC158 MICROSTEP DRIVER

- ! 1.5 AMPS/PHASE OUTPUT CURRENT
- ! MICROSTEPPING DRIVE OPERATION
- ! 1,2 ,4 AND 8 SELECTABLE STEP OPERATIONS
- ! OPTO ISOLATED INPUTS
- ! INTERNAL THERMAL SHUTDOWN
- ! MOTOR ON/OFF INPUT
- ! CURRENT REDUCTION
- ! DIMENSIONS: 4.65" X 3.75" X 0.875"



Description

The MBC158 Microstep Motor Driver has an output current capability from 0.2 Amps Minimum to 1.5 Amps Maximum (Peak Rating). The MBC158 driver will operate off 12VDC Minimum to 48VDC Maximum (up to 1.75 Amps). The inputs are Opto-Isolated with a minimum sourcing of 5 mA per input (5VDC Minimum to 12VDC Maximum). The clock input is set to receive negative edge clocks with a maximum frequency of 100K Hz. The direction input is current sourcing for CW and no current for CCW. The ON/OFF feature is current sourcing to de-energize the step motor and no current to energize the motor. Reduce Current Enabled automatically reduces Motor current 50% after last step (20 msec delay). The +5VDC output supply is dependent on the input DC Supply Voltage (200mA @ 48VDC, 450mA @ 24VDC and 1000mA @ 12VDC). The driver has built-on features to indicate power on (Green LED) and Clocks being received, greater than 100 Hz (Yellow LED).

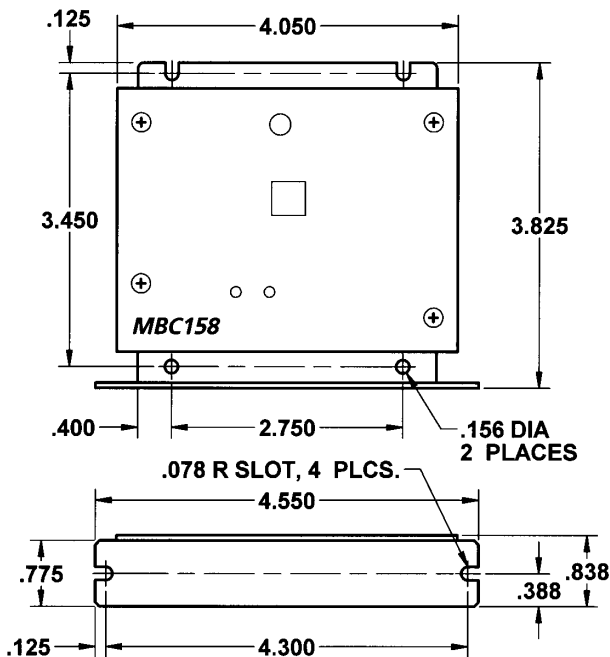

MBC158 Dimensions

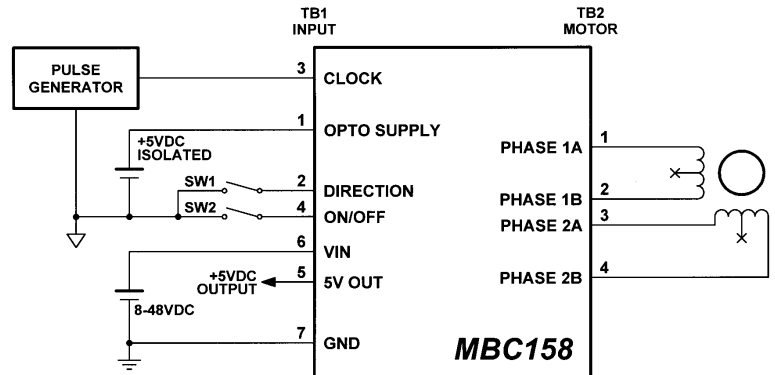

POTENTIOMETER	AMPS
0%	0.2
10%	0.33
20%	0.46
30%	0.59
40%	0.72
50%	0.85
60%	0.98
70%	1.11
80%	1.23
90%	1.36
100%	1.50



910 E. Orangefair Lane
Anaheim, CA 92801-1195

(714) 992-6990 Fax (714)992-0471
Website: www.anaheimautomation.com

CONNECTOR TB1 (INPUT)

Pin	Name	Description
1	OPTO SUPPLY	5VDC Minimum to 12VDC Maximum @50mA maximum is required to power the opto-isolated inputs (Clock, Direction and On/Off).
2	DIRECTION	The DIRECTION input controls the direction in which the motor steps. If the DIRECTION input is high the motor will step in the counterclockwise(CCW) direction. The directions are defined looking in to the shaft of the motor. Note that the order of connection of the motor leads to the driver outputs affects the direction in which the motor turns.
3	CLOCK	The CLOCK input is the stepping clock for the driver. When the clock input transitions from high to low, the motor takes one step.
4	ON/OFF	The ON/OFF input controls the motor. If the ON/OFF input is high, the motor will step with the clock and will have holding current at standstill. If the ON/OFF input is low the motor will be turned off with no holding current and clock signals will be ignored. When the ON/OFF input becomes high again, the motor will hold at the step it was in when the ON/OFF input went low.
5	5VOUT	The 5VOUT pin provides a regulated 5VDC output from the driver. The +5VDC output supply is dependent on the input DC Supply Voltage (200mA @ 48VDC, 450mA @24VDC and 1000mA @ 12VDC).
6	+VIN	Input power supply requirement is 12VDC minimum to 48VDC maximum.
7	0 VDC	This pin is the return/ reference point for +VIN and +5VOUT.

The logic inputs to the MBC158 are of the sourcing type, meaning that an input left open will automatically be pulled up to a high level. To drive an input low, tie it to ground directly or use a saturated transistor.

CONNECTOR TB2 (OUTPUT)

Pin	Name	Description
1	Phase1A	Motor Phase A or Phase 1.
2	Phase1B	Motor Phase /A or Phase 3.
3	Phase2A	Motor Phase B or Phase 2.
4	Phase2B	Motor Phase /B or Phase 4.

MICROSTEP MODES (SW SETTINGS)

MICROSTEP MODES	DIP SW1	DIP SW2	DIP SW3	Auto Reduce Current
Full Step	OFF	OFF	OFF	DISABLED
Half Step	ON	OFF	OFF	DISABLED
Quarter Step	OFF	ON	OFF	DISABLED
Eighth Step	ON	ON	OFF	DISABLED
Full Step	OFF	OFF	ON	ENABLED
Half Step	ON	OFF	ON	ENABLED
Quarter Step	OFF	ON	ON	ENABLED
Eighth Step	ON	ON	ON	ENABLED

SPECIFICATIONS

Inputs (All)	Opto-isolated, minimum sourcing of 5 mA per input (5VDC Minimum to 12VDC maximum) applied to Opto Supply input.
Continuous Output Current	200mA minimum to 1500mA maximum (peak rating). If Reduce Current is Enabled the drive will automatically reduce motor current to 50% of setting after the last step pulse is received (20 msec delay).
Supply Voltage	12 - 48VDC
Clock Frequency	0 - 100kHz minimum pulse width required is 3 microseconds.
Chopping Frequency	22kHz
+5V DC	The +5VDC output supply is dependent on the input DC Supply Voltage (200mA @ 48VDC, 450mA @ 24VDC and 1000mA @ 12VDC).
Operating Temperature	0 - 70E C over the operating voltage and current range. It is recommended that the driver be mounted to a aluminum heat sink or other heat conducting surface.