

# USER'S MANUAL

## MODEL DPS32001 and DPS32PS1 DRIVER PACK



### ***ANAHEIM AUTOMATION***

***910 E. Orangefair Lane***

***Anaheim, CA 92801***

***Phone: (714) 992-6990***

***Fax: (714) 992-0471***

***<http://www.anaheimautomation.com>***

***email: [info@anaheimautomation.com](mailto:info@anaheimautomation.com)***

# TABLE OF CONTENTS

---

	PAGE
INTRODUCTION .....	2
DIMENSIONS .....	2
DESCRIPTION and FUNCTION .....	3
BLD72 BILEVEL DRIVE .....	3
FAULT PROTECTION .....	4
DRIVER JUMPER SETTINGS .....	4
DRIVER HOOKUP DRAWING .....	5
SPECIFICATIONS .....	6
TROUBLESHOOTING .....	7
STANDARD MOTOR TORQUE-SPEED CURVES .....	8

## **COPYRIGHT**

© 1997 by Anaheim Automation. All rights reserved. No part of this publication may be reproduced, transmitted, transcribed, stored in a retrieval system, or translated into any language, in any form or by any means, without the prior written permission of Anaheim Automation, 910 E. Orangefair Lane, Anaheim, CA 92801.

## **DISCLAIMER**

Though every effort has been made to supply complete and accurate information in this manual, the contents are subject to change without notice or obligation to inform the buyer. In no event will Anaheim Automation be liable for direct, indirect, special, incidental, or consequential damages arising out of the use or inability to use the product or documentation. Anaheim Automation does not recommend the use of its' products in life support applications wherein a failure or malfunction of the product may directly threaten life or injury. The user of Anaheim Automation products in life support applications assumes all risks of such use and indemnifies Anaheim Automation against all damages.

## **LIMITED WARRANTY**

All Anaheim Automation products are warranted against defects in workmanship, materials and construction, when used under Normal Operating Conditions and when used in accordance with specifications. This warranty will be in effect for a period of twelve months from the date of purchase or eighteen months from the date of manufacture, whichever comes first. Warranty provisions may be voided if products are subjected to physical modifications, damage, abuse, or misuse.

Anaheim Automation will repair or replace at its' option, any product which has been found to be defective and is within the warranty period, provided that the item is shipped freight prepaid, with previous authorization (RMA#) to Anaheim Automation's plant in Anaheim, California.

## **TECHNICAL SUPPORT**

If you should require technical support or if you have problems using any of the equipment covered in this manual, please read the manual completely to see if it will answer the questions you have. Be sure to look in the TROUBLESHOOTING section located near the back of this manual. If you need assistance beyond what this manual can provide, contact your Local Distributor or the factory direct.

## **TRADEMARKS**

Driver Pack is a registered trademark of Anaheim Automation.

# INTRODUCTION

The ANAHEIM AUTOMATION DPS32001 is a step motor Driver Pack that can drive motors rated from 0.5 to 3.5 amps/phase (unipolar rating). DPS32001 can handle 6-lead and 8-lead motors. This Driver Pack features a unipolar bilevel (or dual voltage) drive technique with short/open circuit protection (with a Fault LED). Outstanding motor performance is provided by means of a Bilevel Drive technique. The DPS32001's open frame construction is ideal for OEM because of its cost-effective design.

DPS32001 Driver Pack features include:

- **Bilevel Drive Operation**
- **100 Watt Transformer**
- **110/220V Operation**
- **Short Circuit Protection**
- **Open Motor Protection**
- **Fault LED**
- **5 Amps/Phase Operating Current**
- **3.5 Amps/Phase Output Current**
- **Unipolar Operation**
- **Half-Step and Full-Step Operation**
- **Motor On/Off Input**
- **No RFI or EMI Problems**
- **TTL/CMOS Compatible Inputs**
- **Optional +5Vdc Regulated and +12 Unregulated Voltage Supply, order Model DPS32PS1**

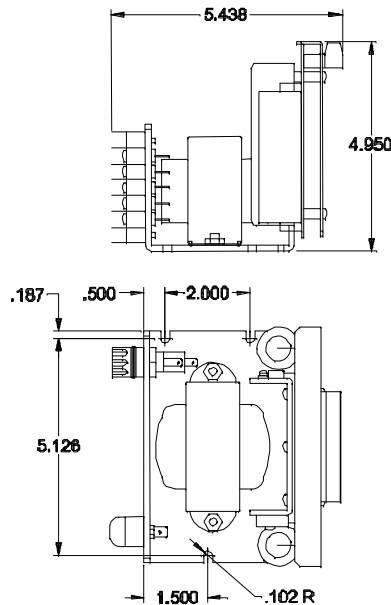

FIGURE 1: DIMENSIONS

# DESCRIPTION AND FUNCTION

## BILEVEL DRIVER

The basic function of a motor driver is to provide the rated motor phase current to the motor windings in the shortest possible time. The bilevel driver uses a high voltage to get a rapid rate of current rise in the motor windings in the least amount of time. When reaching the preset trip current, the driver turns off the high voltage and sustains the current from the low voltage supply.

## EXCITATION MODE SELECT

Users have a choice of dual-phase, full-step operation or half-step operation. Dual-phase, full-step operation occurs by energizing two phases at a time, rotating a typical motor 1.8 degrees per step. Half-step operation occurs by alternately energizing one, and then two, phases at a time, rotating the motor 0.9 degrees per step. Full-step operation is only suggested for applications that specifically require that mode, such as when retrofitting existing full-step systems.

## STEP AND DIRECTION CONTROL

Clock and Direction, or Dual Clock operation. The Direction Input or CCW Input can be selected by placing jumpers in the appropriate positions (see Table 2). Pulses applied to the Clock input cause the motor to step in the clockwise direction if the Direction Input is a logic "1" or the counterclockwise direction if the Direction Input is a logic "0". Pulses applied to the CCW Input cause the motor to step in the counterclockwise direction. Either positive or negative going pulses may be used by setting jumpers to the appropriate positions (See Table 2).

## +5V POWER SUPPLY (Optional, Order Model Number DPS32PS1)

This power supply is capable of supplying up to 1.0A to other devices or circuitry. The +12V unregulated voltage may also be used for supplying current to external loads up to 1.5Amps. These outputs can only source a combined total of 1.5 Amps maximum.

## MOTOR ON/OFF INPUT

The Motor On/Off input allows for de-energizing a motor without disturbing the positioning logic. After re-energizing the motor, a routine can continue. This reduces motor heating and conserves power, especially in applications where motors are stopped for long periods and no holding torque is required.

## ADJUSTING KICK CURRENT

By following the silkscreen markings on the side-plate, use a small screwdriver to adjust the potentiometer. Line up the arrow to the number corresponding to the motor's rated current (amps/phase). The kick current is preset for 40 percent over the motor's rated amps/phase.

## FAULT PROTECTION

There are three types of fault detection. When a fault is detected, the driver turns off the motor current and the red Fault LED indicates which type of fault occurred. See the Troubleshooting section for more information.

CONDITION		FAULT DETECTED
1	LED - Slow Blink	shorted wire in the motor or cable
2	LED - Fast Blink	open wire in the motor or cable
3	LED - ON Steady	ground fault (voltage shorted to 0V)

TABLE 1: TYPE(S) OF FAULT(S)

If the driver goes into a fault condition, the fault may be reset by turning the power OFF for at least 15 seconds, or by pulling the RESET FAULT input (terminal 4) to a Logic "0" for at least 100ms.

FUNCTION	JP1	JP2	JP3
NEGATIVE GOING CLOCKS	1-2	X	X
POSITIVE GOING CLOCKS	2-3	X	X
TERMINAL 5 = CCW	X	1-2	X
TERMINAL 5 = DIRECTION	X	2-3	X
GROUND FAULT DETECTION ENABLED	X	X	2-3
GROUND FAULT DETECTION DISABLED	X	X	1-2
STANDARD PRODUCT	1 - 2	2 - 3	2 - 3

TABLE 2: JUMPER SETTINGS

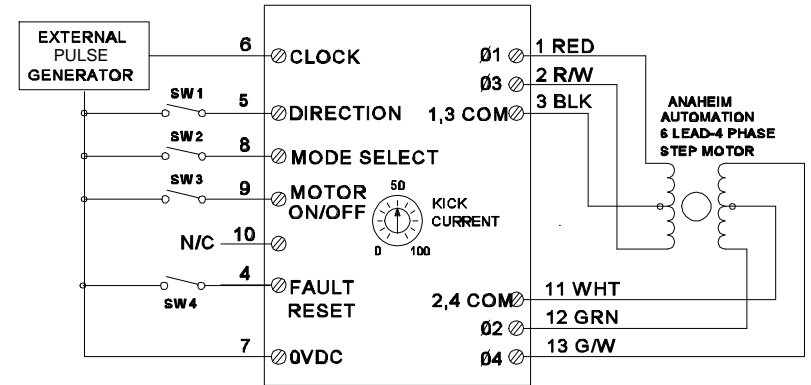

FIGURE 2: HOOKUP DIAGRAM USING CLOCK AND DIRECTION.

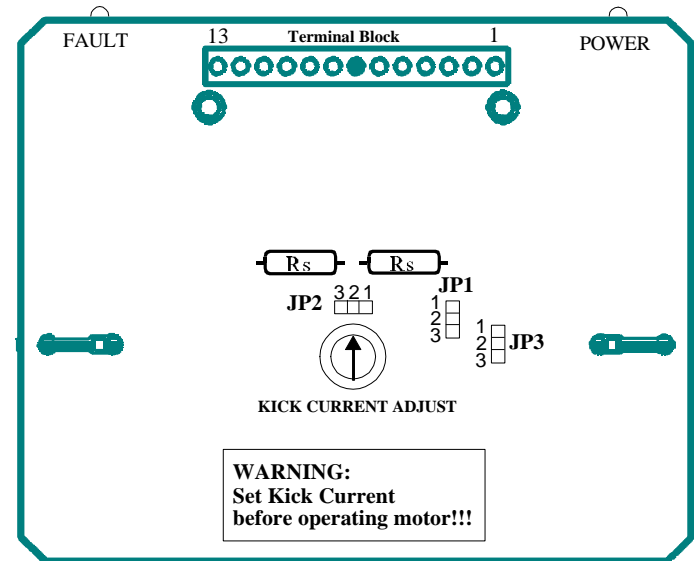

FIGURE 3: JUMPER LOCATIONS.

# SPECIFICATIONS

## DRIVER SPECIFICATIONS (BLD72/AA3020D)

CONTROL INPUTS (All) : (Terminals 5, 6, 8, 9)

TTL-compatible

Logic "0" - 0 to 0.8 V

Logic "1" - 3.5 to 5.0 V

CLOCK INPUTS: (Terminal 6)

15 microseconds minimum pulse width required. The Clock Inputs are internally pulled up to +5Vdc through a 10KΩ resistor.

DIRECTION CONTROL: (Terminal 5)

Logic "1" (open) - CW motor direction

Logic "0" - CCW motor direction

EXCITATION MODE SELECT: (Terminal 8)

Logic "1" - Half-step

Logic "0" - Full-step

MOTOR ON/OFF: (Terminal 9)

Logic "1" (open) - motor current on

Logic "0" - motor current off

OUTPUT CURRENT RATING:(Terminals 1, 2, 3, 11, 12, & 13)

5 Amps per phase maximum operating or running current, and 3.5 Amps per phase maximum standstill current. Motor phase ratings of 0.5 Amp minimum are required to meet the minimum kick level.

POWER SUPPLY OUTPUTS: (Optional on Model DPS32PS1)

+5VDC output: 1.5 Amps absolute maximum \*

(see paragraph on +5VDC OUTPUT)

+12VDC unregulated output: 1.5 Amps maximum \*

\* Maximum of 1.5A total can be drawn from both of these outputs simultaneously.

OPERATING TEMPERATURE : 0 to 60 Degrees Celsius

The user must take into consideration where the unit is mounted, the duty cycle of operation and the ambient temperature. Care should be taken so that no point on the chassis exceeds 60 Degrees Celsius.

FUSE RATING: 2 Amp Slow Blow, 3AG

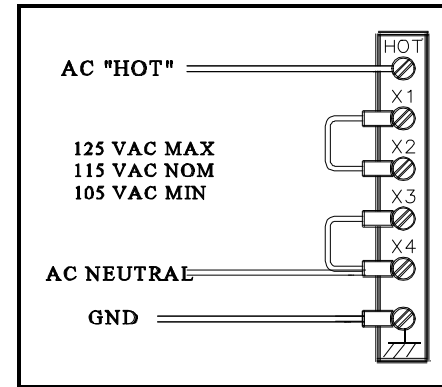

FIGURE 4: HOOKUP FOR 110VAC  
105VAC to 125VAC, 50-60Hz

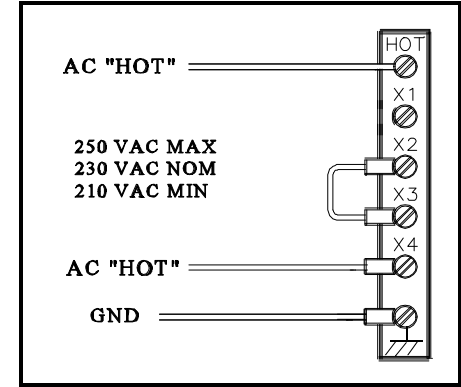

FIGURE 5: HOOKUP FOR 220VAC  
210 to 250VAC, 50-60Hz

## POWER REQUIREMENT: TROUBLESHOOTING DRIVER FAULTS

If a Fault occurs, reset the Fault by applying a Logic "0" to the Reset Fault Input (terminal 4) for at least 100ms (or by cycling power OFF for at least 15 seconds). After resetting, try to run the motor again. If the driver faults again, check the conditions listed below.

### Is the LED blinking Slowly?

This indicates that the motor has a phase shorted or there is a short in the motor cable or wiring. Check the motor and the wiring for shorts. If the driver continues to sense "shorts" after the motor and wiring are determined to be good, then the output transistors should be checked (see below).

### Is the LED blinking Quickly?

This indicates that there is an open connection in one of the motor wires. Check the motor and the wiring for opens. Another condition that may cause this type of fault is when a large motor is ramped down too quickly so that it loses its positioning.

### Is the LED on Steadily?

This indicates that there is a ground fault - a voltage shorted to 0V. This detection is useful in detecting a short-to-case in a motor when the motor's case AND the driver's 0V are both connected to earth ground. Excessive noise on the 0V line may also cause the driver to sense this type of fault. This type of fault sensing may be disabled by placing jumper JP3 in position "1-2" (see figure 3).

*NOTE: IF THE GROUND FAULT DETECTION IS DISABLED, DO NOT*

## CONNECT THE DRIVER'S 0V TO EARTH GROUND!

### Checking Output Transistors

1. Set the multimeter to Diode Test.
2. Place the RED meter lead on (between) the Sense Resistors (labeled Rs in Figure 4).
3. Touch the BLACK meter lead to each phase (terminals 1, 2, 12, and 13).
4. This should give readings between 0.450V and 0.550V.
5. If any readings are significantly less than 0.450V, then the unit has been damaged. To send the unit in for repair, contact the factory for an RMA#.

## TTORQUE/SPEED PERFORMANCE CURVES

