

DPFHP001 HIGH PERFORMANCE BILEVEL STEP MOTOR DRIVER PACK

- Very High Motor Power Output
- 15 Amperes/phase Maximum Operating Current
- 10 Amperes/phase Standstill motor current
- Internal Dual Voltage Power Supply
with 500VA Transformer
- High Start-Stop Speeds
- Transient Voltage Suppression
- Halfstep and Fullstep Operation
- Bilevel Drive Operation (No RFI or EMI problems)
- TTL/CMOS Compatible Inputs
- Clock and Direction or Dual Clock Operation
- Motor Turn-off Input
- +5VDC Output

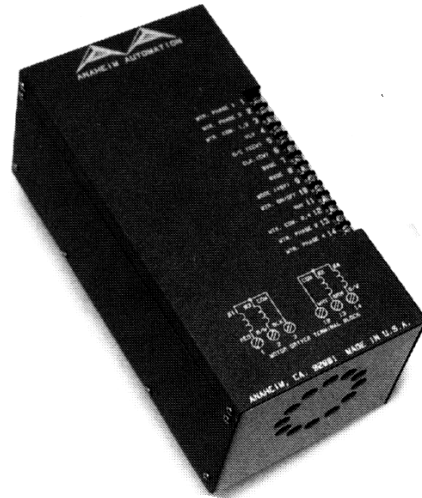

GENERAL DESCRIPTION

The Anaheim Automation DPFHP001 Step Motor Driver Pack is designed for motor applications that require very high power output and high start-stop step rates. Outstanding motor performance is achieved by means of an enhanced bilevel or dual-voltage drive technique. This Driver Pack contains a high performance driver board (BLHP101), a 500VA transformer, and a dual power supply. It may be used with six or eight lead, size 34 and 42 step motors whose phase current ratings range from 2 to 12.5 amperes per phase.

BILEVEL DRIVE

The basic function of a step motor driver is to control the motor winding currents. Motor performance is determined by how fast the driver can increase and decrease the winding currents. A rapid rise in winding current is achieved by applying a high voltage directly to a motor. This rapid rise of current is also referred to as the "kick" or operating current. When a desired current level is reached, a low voltage is applied to maintain a suitable holding current level. When a motor winding is DPFHP001 Driver Packs are shipped

turned off, a rapid decrease in winding current is achieved by routing the energy in the collapsing field back to the power supply through a high voltage path. The high voltage supply furnishes the energy necessary to maintain motor output torque at high step rates thus providing high mechanical power output. The low voltage supply provides much of the current needed at low step rates and all of the holding current.

Bilevel drivers do not use high frequency switching techniques as chopper drivers do. Consequently, they do not create the EMI, RFI, and motor heating problems that are associated with chopper drivers.

TRANSIENT VOLTAGE SUPPRESSION

Transient Voltage Suppression (TVS) Diodes on the motor phase outputs allow for much longer motor cables to be used. Normally when using long motor cables, voltage transients and spikes are created. These transients often exceed the voltage ratings of the output phase transistors, resulting in blown transistors. The addition of the from the factory with terminal 9

TVS Diodes suppresses these transients and protects the transistors against damage.

CLOCK AND DIRECTION/ CCW OPERATION

DPFHP001 Driver Packs are shipped from the factory with terminals 6 and 5 assigned as CLOCK and DIRECTION inputs respectively. Pulses applied to the CLOCK input cause the motor to step in the clockwise direction if the DIRECTION input is at a logic "1" (or no connection), or in the counterclockwise direction if the DIRECTION input is at a logic "0". By setting JP1 to the "1-2" position, terminal 5 becomes the CCW (Counterclockwise Clock) input. Pulses applied to the CCW input cause the motor to step in the counterclockwise direction. Either positive or negative going pulses may be used by setting JP3 to the appropriate position. See Figure 1 and Table 1 for Jumper locations and settings.

MODE SELECT/+5V OUTPUT

assigned as an excitation Mode Select



A N A H E I M A U T O M A T I O N

910 East Orangefair Lane, Anaheim, CA 92801
e-mail: info@anaheimautomation.com

(714) 992-6990 fax: (714) 992-0471
website: www.anaheimautomation.com

input. The Mode Select input is used to select either halfstep or fullstep motor operation. Halfstep operation is generally preferred because this mode provides better resolution, minimizes resonance effects, and reduces power consumption. The motor steps in increments of half the natural step angle, e.g. in 0.9 degree steps for a 1.8 degree step motor. In fullstep operation, the motor steps in 1.8 degree steps. By setting JP2 to the "1-2" position, terminal 9 becomes a +5VDC regulated output. The driver defaults to halfstep when the +5VDC output is used.

MOTOR ON/OFF INPUT

The MOTOR ON/OFF input can be used to turn off all four motor phases (de-energize the motor) in applications where motor detent torque is sufficient to maintain the load position. This feature can be used to reduce the load on the power supply and the heat dissipation in the driver circuitry and

TABLE 1: Jumper Description.

motor. Terminal 10 is the MOTOR ON/OFF Input.

X=DONT CARE

ADJUSTING THE KICK CURRENT

The kick (or operating) current level is the desired phase current level that the high voltage provides each time a step is taken. The high voltage is turned off when this level is reached. The kick current level should be set to approximately 1.4 times the rated phase current. For example, a motor rated at 10 amps/phase should be "kicked" to 14 amps. Table 2 shows various kick current levels for corresponding phase currents. When using a motor listed in Table 3, use the recommended potentiometer setting.

WARNING: The kick current level must be set before operating a motor.

MOTOR DRIVER CONNECTIONS

Motor wires are connected to the driver pack through terminals 1, 2, 3, 12, 13, and 14. Electrical connections to control inputs should be kept physically

separated from the motor connections. Wiring from the driver to the motor should be routed away from all other wiring. Hookup diagrams are shown in Figures 2 and 3.

CONNECTOR P1

This 14-pin header type connector is used for a direct connection from the DPFHP001 to Anaheim Automation Standalone Indexers such as the CL2541P. The DPFHP001 powers up the indexer through the 14-pin cable and receives Clock, Direction, and other signals from the indexer through the same cable. See Table 4.

MOUNTING AND COOLING

The DPFHP001 contains an internal fan to create airflow through the unit. Heating considerations should include where the unit is mounted, the duty cycle of operation, ambient temperature, etc. Care should be taken so that no point on the chassis exceeds 60 degrees Celsius.

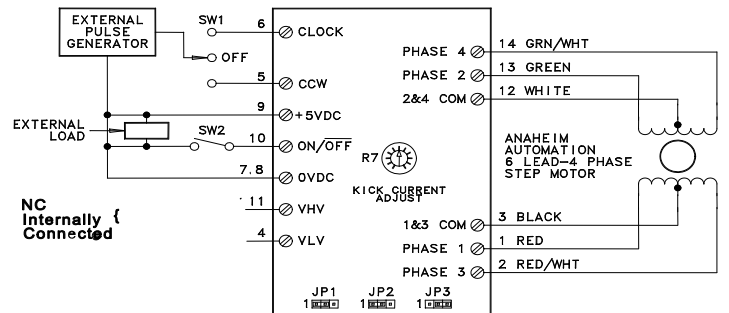
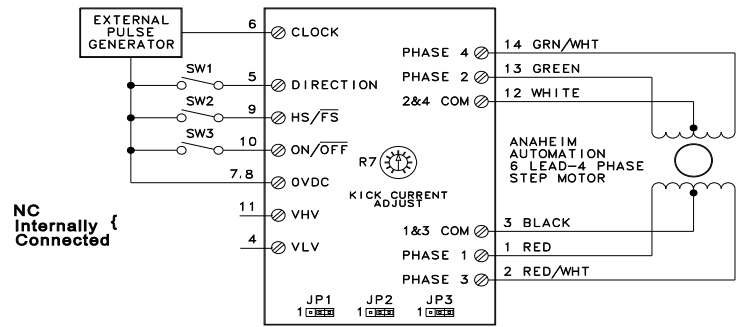

JUMPER DESCRIPTION	JP1	JP2	JP3
TERMINAL 5 = DIRECTION	2-3	X	X
TERMINAL 5 = CCW	1-2	X	X
TERMINAL 9 = HS/FS	X	2-3	X
TERMINAL 9 = +5VDC OUTPUT	X	1-2	X
POSITIVE GOING CLOCK INPUTS	X	X	2-3
NEGATIVE GOING CLOCK INPUTS	X	X	1-2
STANDARD PRODUCT (READY TO SHIP)	2-3	2-3	1-2

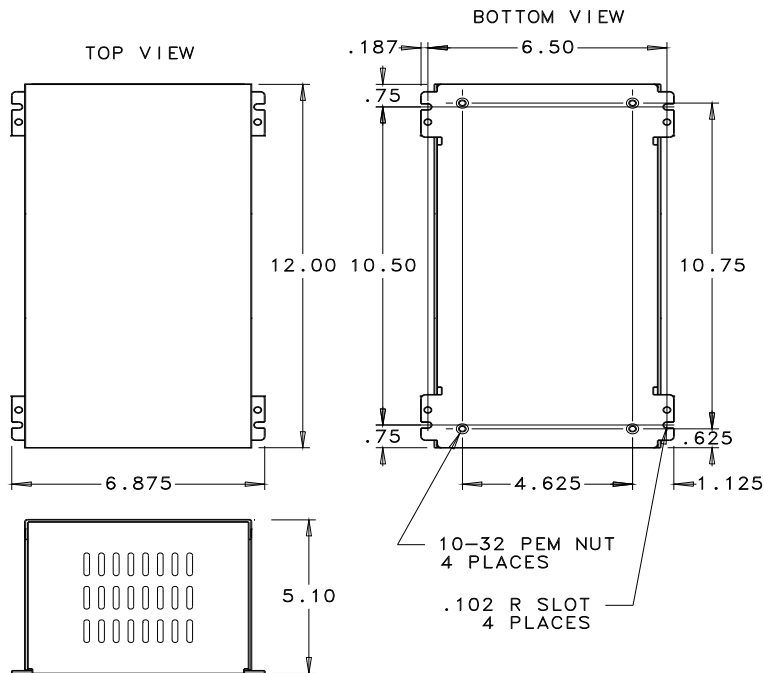
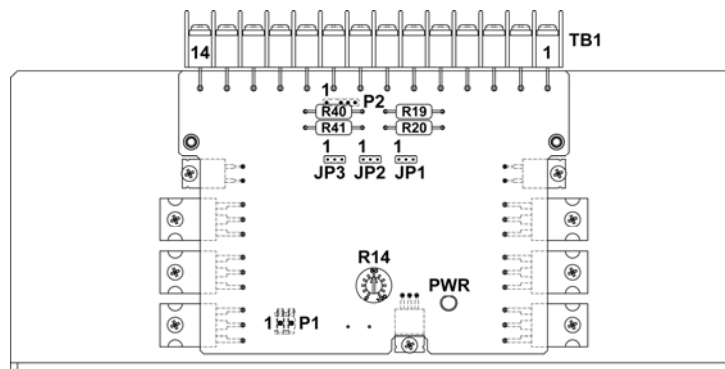

SPECIFICATIONS:

POWER REQUIREMENTS

105 VAC to 125 VAC for DPFHP001

210 VAC to 250 VAC for DPFHP001x220

CONTROL INPUTS

(Terminals 5,6,9,10):

Logic "0": 0 to 0.8 VDC.

Logic "1": 3.5 to 5 VDC.

CLOCK Input: (Terminal 6)

This input is either pulled down (for positive going pulses) or up (for negative going pulses) through a 10k ohm resistor (set by JP3). A pulse width of 15 microseconds minimum is required to step the motor. The maximum control pulse rate is limited by motor performance.

DIRECTION/CCW Input: (Terminal 5)

When programmed as DIRECTION input (set by JP1), this input is internally pulled up to +5VDC through a 10k ohm resistor. When a logic "1" (or no connection) is applied, the motor will step in the clockwise direction when pulses are applied to the CLOCK input. Similarly, when a logic "0" is applied, the motor will step in the counterclockwise direction when pulses are applied to the CLOCK input. When programmed as CCW input, the motor will step in the counterclockwise direction when pulses are applied to this input (pulse requirement is same as for CLOCK input).

MODE SELECT/+5VDC OUTPUT: (Terminal 9)

When programmed as Mode Select Input (set by JP2), this terminal is internally pulled up to +5VDC through a 10k ohm resistor. When a logic "1" (or no connection) is applied, the motor will operate in halfstep mode. When a logic "0" is applied, the motor will operate in fullstep mode. When this terminal is programmed as +5VDC Output, up to 500mA may be used to power up external circuitry. The driver defaults to halfstep when the +5VDC output is used.

MOTOR ON/OFF INPUT: (Terminal 10)

This terminal is internally pulled up to +5VDC through a 10k ohm resistor. When a logic "1" (or no connection) is applied, the driver phase outputs are enabled and the motor is energized. When a logic "0" is applied, the driver phase outputs are disabled and the motor is de-energized.

MOTOR PHASE OUTPUTS: (Terminals 1,2,13,14)

These outputs can sink a peak of 15 Amperes or sink 10 Amperes continuously and stand-off 250 VDC maximum.

MOTOR COMMON OUTPUTS: (Terminals 3,12)

These outputs can source a peak current of 15 Amperes, or source 10 Amperes continuously.

AMBIENT TEMPERATURE: 0 to 50 degrees Celsius.

SHIPPING WEIGHT: 15 pounds

Rated Motor Phase Current	KICK CURRENT
1.4 - 2.4	2.0 - 3.4
2.4 - 3.3	3.4 - 4.6
3.3 - 4.3	4.6 - 6.0
4.3 - 5.4	6.0 - 7.5
5.4 - 6.3	7.5 - 8.8
6.3 - 7.2	8.8 - 10.1
7.2 - 8.1	10.1 - 11.4
8.1 - 8.9	11.4 - 12.5
8.9 - 9.6	12.5 - 13.5
9.6 - 12.5	13.5 - 15.0

Table 2: Potentiometer Settings for Kick Current.

P1 Pin	Description
1	N/C
2	N/C
3	+12V UNREG.
4	N/C
5	DIRECTION
6	MOTOR ON/OFF
7	HS/FS
8	N/C
9	N/C
10	CLOCK
11	0VDC
12	N/C
13	0VDC
14	N/C

TABLE 4: 14-Pin Header for Indexer Interfacing.

AA MOTOR	HOLDING CURRENT	KICK CURRENT
34D106	1.95 - 3.00	4.20
34D109	3.12 - 4.80	6.72
34D207	2.28 - 3.50	4.90
34D209	3.00 - 4.60	6.44
34D213	4.23 - 6.50	9.10
34D307	2.28 - 3.50	4.90
34D311	3.58 - 5.50	7.70
34D314	4.55 - 7.00	9.80
42D112	3.97 - 6.10	8.54
42D119	6.18 - 9.50	13.3
42D212	3.97 - 6.10	8.54
42D219	5.98 - 9.20	12.88
42D225	8.25 - 10.00	15.00

TABLE 3 Holding Current and Kick Current Settings for AA Motors.

34D106 and 34D109

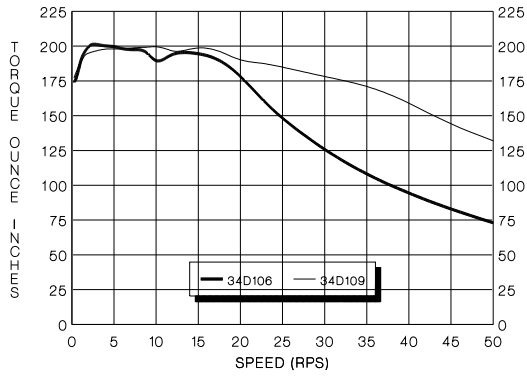

34D307, 34D311, 34D314

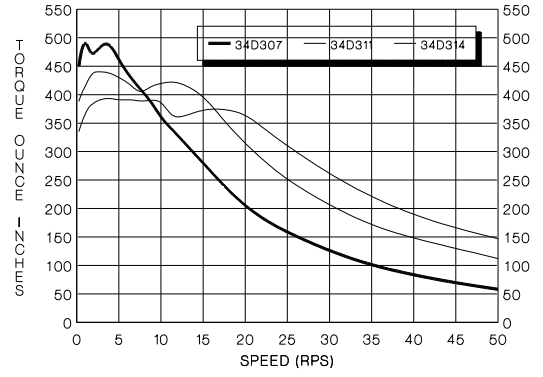

34D207, 34D209, 34D213

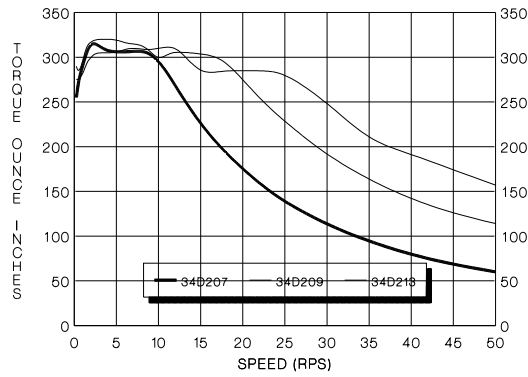

42D112 and 42D119

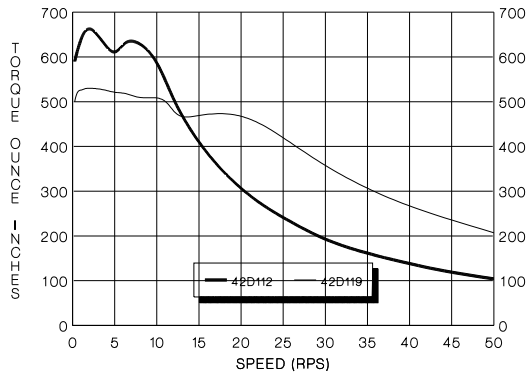

42D212, 42D219, 42D225

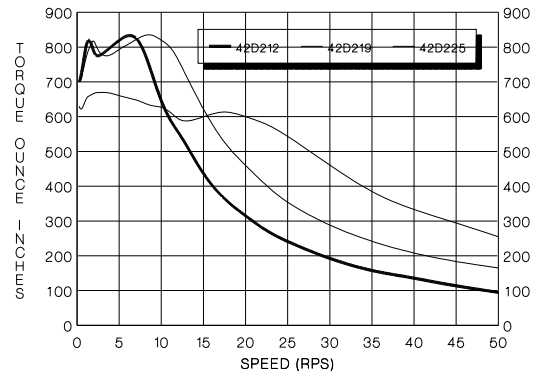

TORQUE/SPEED CURVES